

news

1/2016

Mass and Symmetries after the Discovery

GRK 2044

of the Higgs Particle at the LHC



Dear all,

2016 has been an interesting and busy year for all of us. That is why the Newsletter has been down for a while...but we finally managed to have one issue for this year! I hope you will enjoy the first (and last!) Newsletter of 2016!

If you want to contribute in the future, feel free to send your suggestions to Michele Boggia.

DATES

All dates, news, and updates are given on the website of the GRK 2044: www.grk2044.uni-freiburg.de

Seminar series of the GRK

Remaining seminars on Wednesdays 16 s.t. of this term are:

21.12.2016	Peter Wagner (Universität Bonn)	Reconstruction of tau leptons and physics with tau leptons with ATLAS	abstract	HS II, 16st
11.01.2017	Student talks	t. b. a.		HS II, 16st
18.01.2017	Stefano Pozzorini (Universität Zürich)	NLO automation with OpenLoops + Sherpa	abstract	HS II, 16st
25.01.2017	Martin Beneke (TU München)	Pole mass, renormalon and perturbative QCD		HS II, 16st
08.02.2017	Sven Heinemeyer IFT/IFCA (CSIC, Madrid/Santander)	SUSY @ LHC		HS II, 16st

If you have suggestions for future speakers, please contact Alena Lösle and Gernot Knippen.

Welcome to the new GRK PhDs of 2016!

Some of them have already been here quite a few months... But there are some new comers as well. Welcome aboard to Evgenij (Ita), Julian (Jakobs), Katharina (Schumacher), Sven (Jakobs) and Veronika (Herten)!

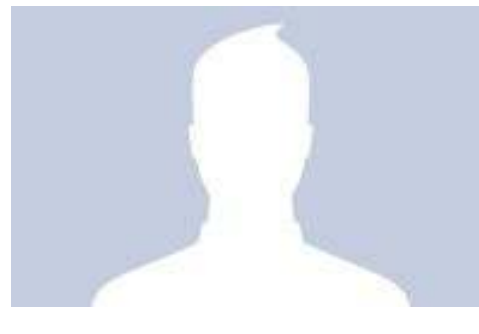

SERIES: Members of our GRK: The ATLAS tracker upgrade

The LHC ATLAS experiment, in which Freiburg is involved, is aiming to answer some of fundamental questions such as the origin of mass, the nature of dark matter and so on. Both LHC and ATLAS have shown great performance so far and have produced significant results. In fact, ATLAS has already published more than 500 scientific papers including the Higgs discovery paper. However, the scientific program of LHC spans over the next 20 years to extend the scientific potential of the experiments. The HL-LHC project, which will start in the middle of 2026, is one of the core projects. The HL-LHC would provide data which allow us to perform a precise measurement of the Higgs properties and which could potentially give us a clue for new physics. On the other hand, the HL-LHC is a big challenge for ATLAS since it operates at a peak instantaneous luminosity of up to 7.5×10^{34} [cm²-s⁻¹], corresponding to approximately 200 proton-proton collisions per beam crossing. The detector must be operational under this harsh condition and also must survive until the HL-LHC will end its ten-year long operation. This fact requires us to make a significant upgrade of the detector.

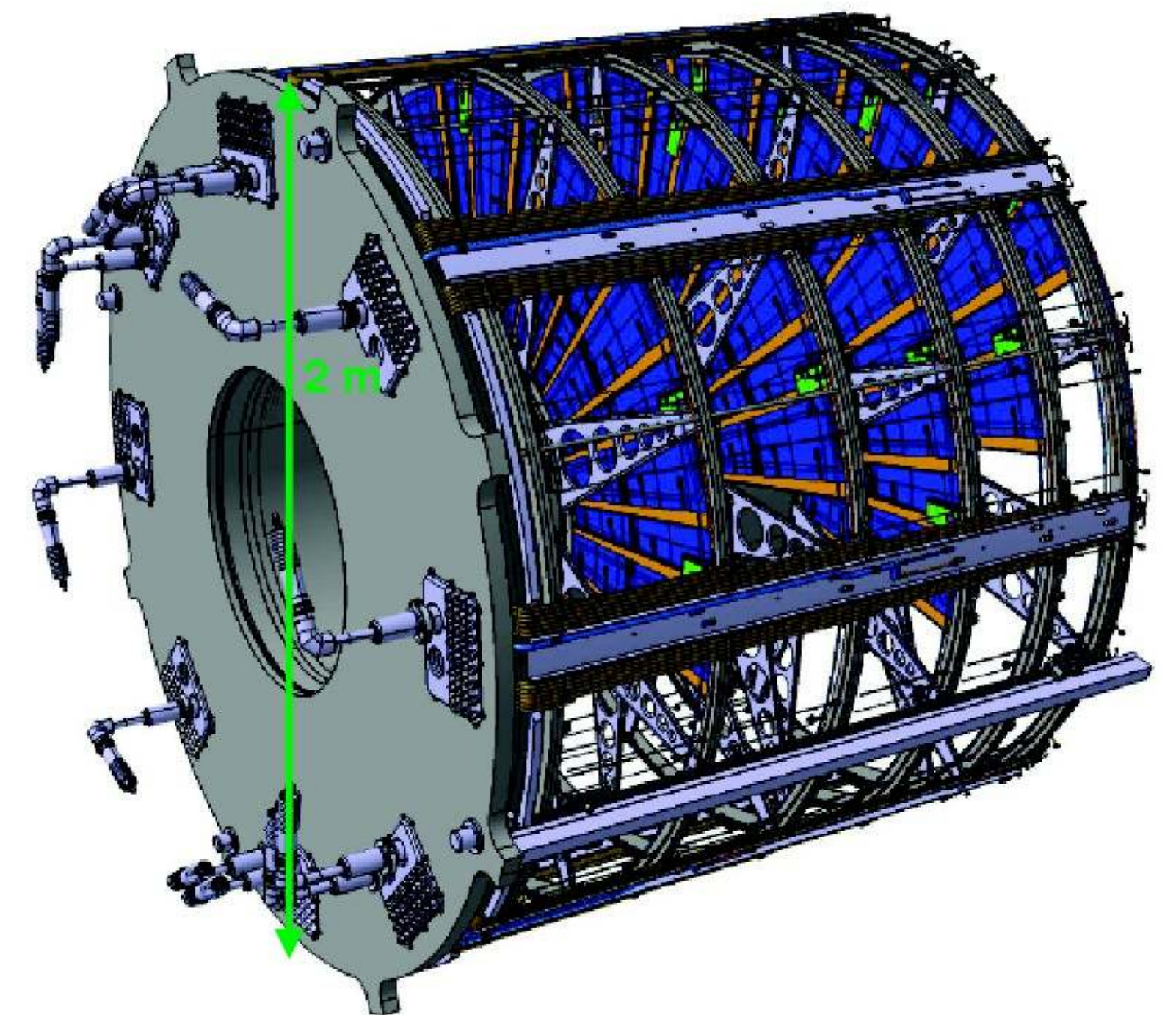

Petal (9 modules)

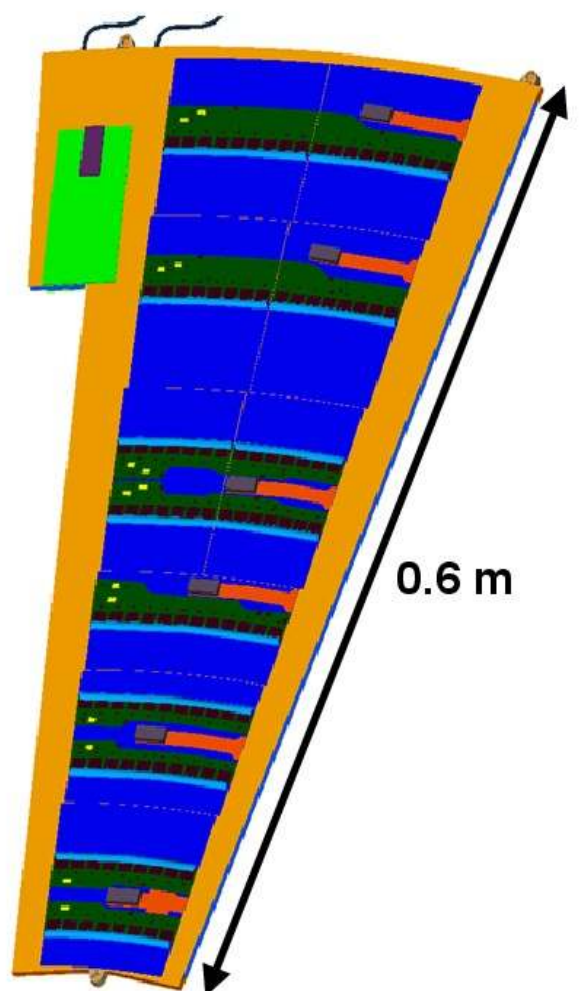

Prototype module

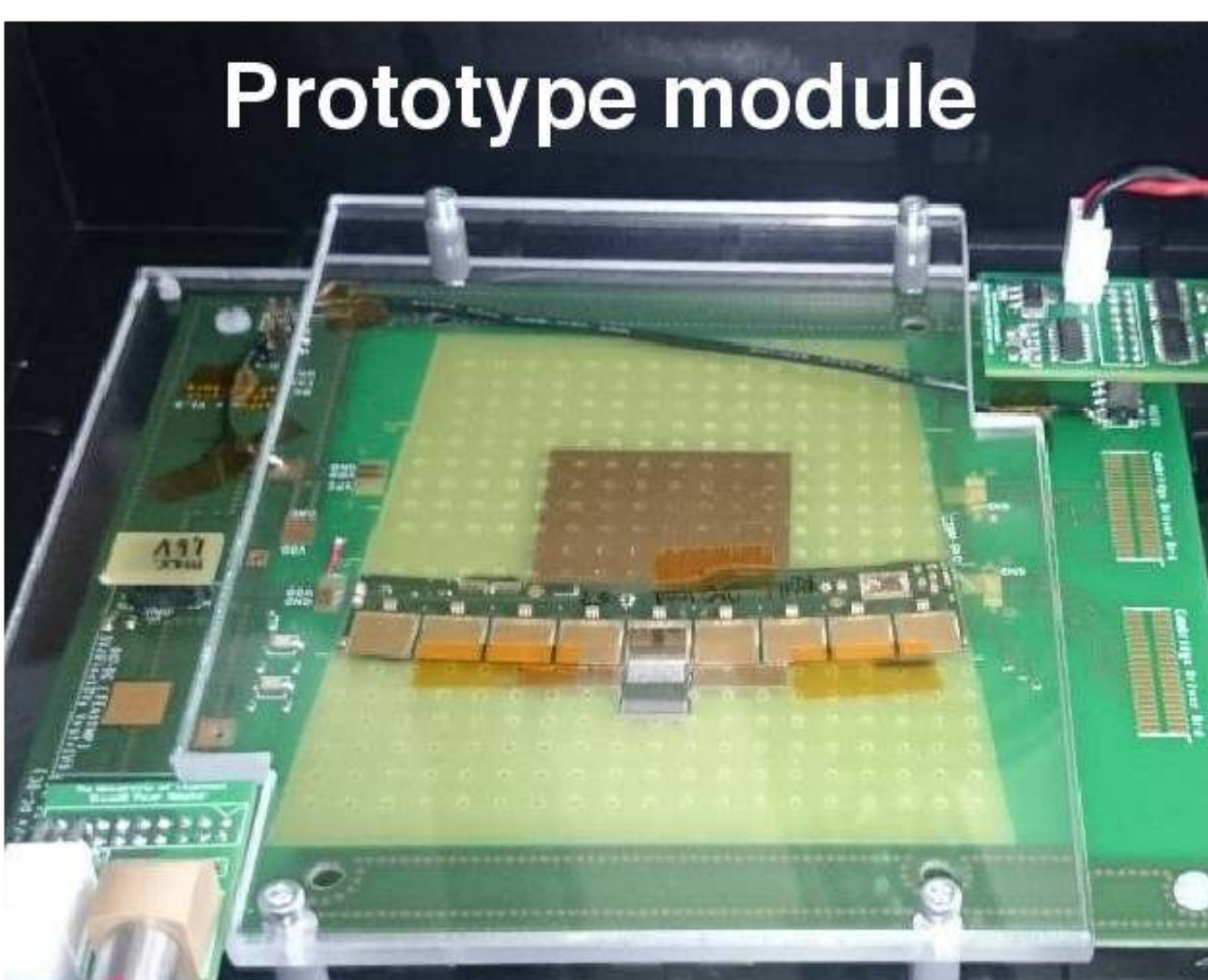

The Freiburg group is involved in the upgrade activity of the inner tracking system, more specifically of the silicon strip detector. The silicon strip detector works in a magnetic field so that the trajectory of particles can be reconstructed. This information is essential to achieve high performance in the physics analyses, especially in the high particle density environment expected at the HL-LHC. The Freiburg group is working on designing an endcap detector module and the measurement of characterisations of prototype strip detectors. The endcap detector is very important to cover the solid angle around the proton-proton interaction region as much as possible. It is one of the challenges to achieve a hermetic detector while keeping a lower material budget. We managed to finalize the design of the several types of modules in this year. Prototypes were already made and under test.

Despite the HL-LHC will start in 10 years, the schedule of production of the upgraded detector is actually tight. At the end of this year, the strip detector community will release the Technical Design Report which is one of the milestones to describe what types of technology will be used for the detector based on all our past R&D effort before the actual mass production. Starting from the next year, Freiburg will work on the preparation of the production at the institute. 2017 will be a critical and exciting year to be confident to start the mass production by testing all the final version detectors!

In case you want to know more, you can talk to the tracker upgrade group: Prof. Dr. Karl Jakobs, Dr. Ulrich Parzefall, Dr. Minoru Hirose, Dr. Susanne Kühn, Dr. Carlos Garcia Argos, Dipl.Phys. Marc Hauser.

New members of the GRK

Marc Schumann

Marc Schumann studied physics at the University of Heidelberg and at the Queen's University in Kingston, Canada. In Heidelberg he also completed his doctoral thesis on precision measurements in low-energy beta decays, and continued to work there as a PostDoc for a few month before moving to Houston, Texas, to continue his research at Rice University. He returned to Europe in 2009, getting a Senior Researcher position in Zurich. Starting 2013, he was working as Assistant Professor for experimental astroparticle physics at the University of Bern. He joined the University of Freiburg as full professor in November 2016, and he is happy to be back in Germany. He will lead a new astroparticle physics group, working on Dark Matter detection within the XENON1T experiment and on the development of XENONnT and the ultimate Dark Matter detector.



Beate Heinemann

Beate Heinemann received her Diploma and PhD from the University of Hamburg in Germany. From 1999-2002 she had a postdoctoral fellowship from the Particle Physics and Astronomy Research Council (PPARC) at the University of Liverpool in the United Kingdom. From 2002-2004 she had a PPARC Advanced Fellowship and from

2004 to 2006 a fellowship from the Royal Society at the University of Liverpool. In 2006 she was appointed Associate Professor of Physics at the University of California Berkeley. Since August 1st, she has accepted a joint appointment by DESY, as leading scientist of the DESY's ATLAS Group, and the University of Freiburg.



From the GRK PhD student speakers:

Dear PhD students,



Since the publication of the last newsletter, which was quite some time ago, lots of events and changes happened. We, Alena and Gernot, took over from the old students speaker team, Giulia and Felix. We warmly thank them for their nice work and outstanding commitment. The students speakers represent you, the PhD students of the GRK2044. Please contact us if you have questions, comments or suggestions. To follow up on the tradition of a regular student meeting we have monthly GK lunches. They usually take place on one of the first Fridays of the month at 12:30 in the Mensa. We discuss upcoming events, decisions and news. We warmly invite you to join us.

This year's most important event was the excellent annual workshop of the GRK2044 in Gengenbach. We would like to thank everybody who contributed with lectures, talks and posters and made the workshop a great success. Our thanks also goes to Christina Skorek for all her work in organizing the workshop.

We are happy to announce that the topics for next term's seminars are almost fixed. We are looking forward to all upcoming talks and discussions. We would like to take the opportunity to kindly remind you of the introductory sessions just before the seminars. If you are interested in contributing, please feel free to sign up and keep in mind that the introductory talks should not exceed 15 minutes. We will continue the successful tradition of having closed discussion sessions after the seminar talks to give you the possibility to ask the speaker any kind of questions without the supervisors being present.

We wish you all merry Christmas, nice holidays and a happy new year.
Alena and Gernot



Non-Physics: New Year's Eve!

You don't want to sit at home on New Year's Eve and watch 'Dinner for One' for the 1000th time?
You don't want to go to bed 10 minutes after the fireworks stopped?
You don't want to be a lame duck?

Then check out one of these parties!

Crash: Rock, Metal, Alternative;

www.crash-musikkeller.de

Harmonie Gewölbekeller: 90s;

www.facebook.com/harmonie.gewolbekeller

Waldsee: Mixed Music; with fireworks at the lake;

www.waldsee-freiburg.de



Karma: Mixed Music; www.karmafreiburg.de

Agar: Mixed Music; www.agar-disco.de

Atlantik: Rock, Punk; www.cafe-atlantik.de

Kagan: House, Trap, RnB; nice view on top of the train station high rise;

www.kagan-freiburg.de

Schmitz Katze: Electro, House; last opening of this club, starts at 0.30;

www.schmitz-katze.com

ANATOMY OF A WINTER BREAK

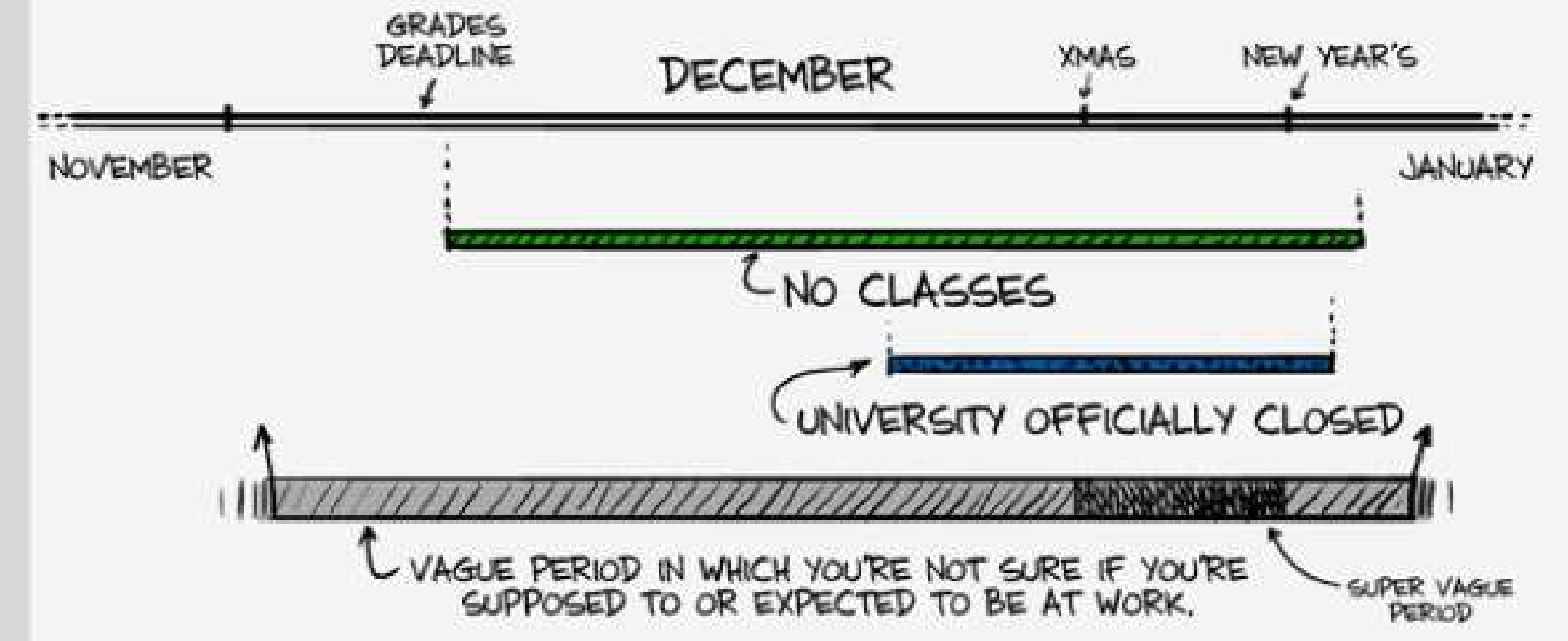

WHAT PEOPLE USUALLY DO OVER WINTER BREAK:

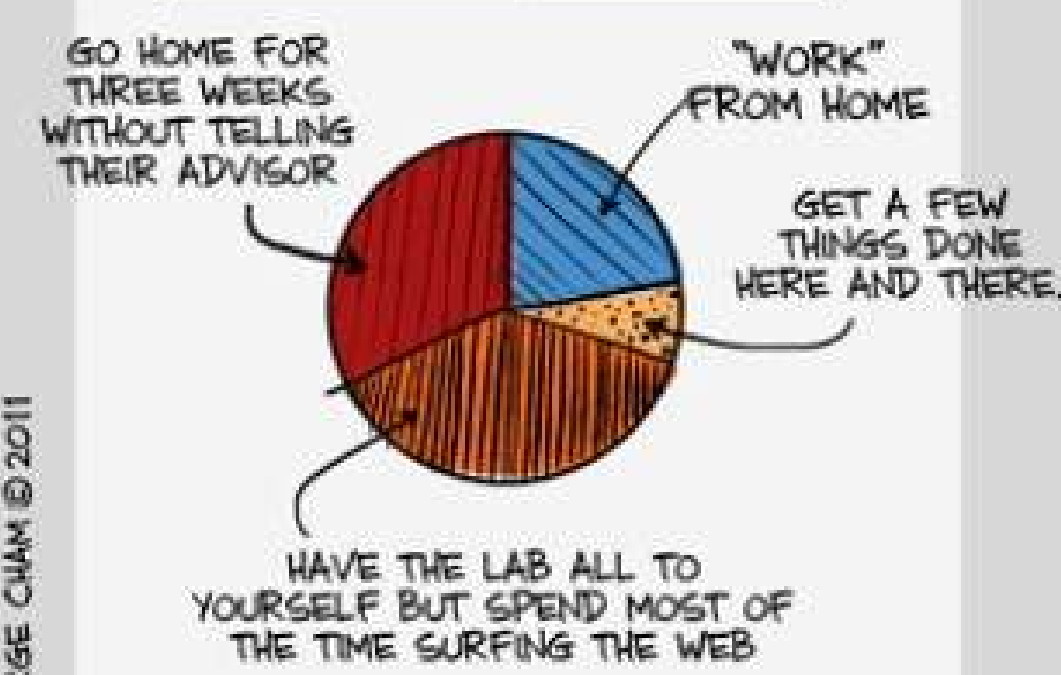

WHEN IT'S OK TO WISH SOMEONE "HAPPY NEW YEAR!":

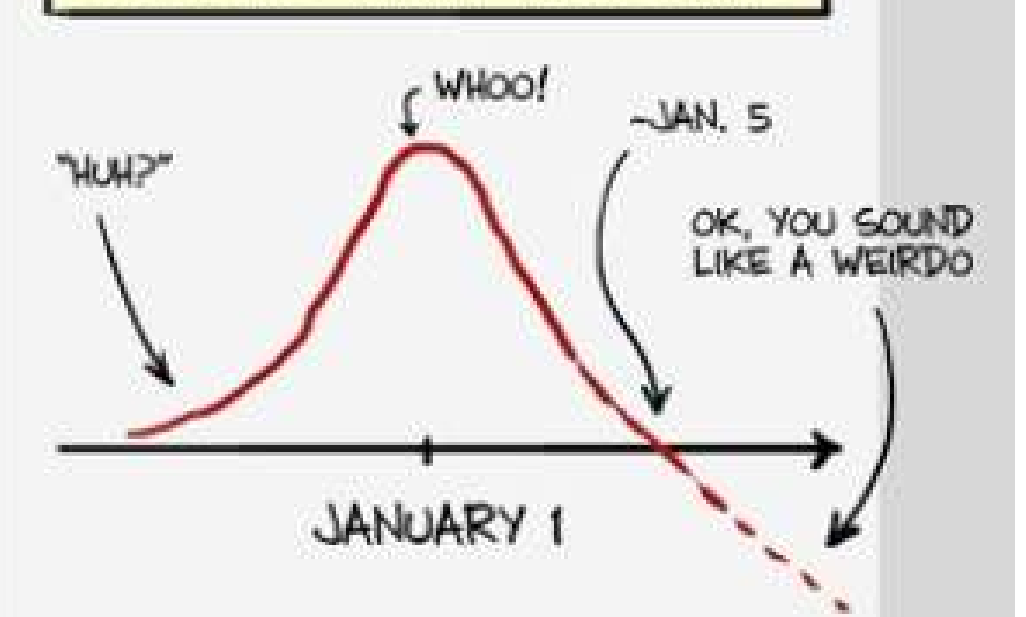

JORGE CHAN © 2011

WWW.PHDCOMICS.COM

Thank you for the contributions to: Minoru Hirose, Marc Schumann, Gernot Knippen, Alena Lösle, Dirk Sammel and Michele Boggia (Editor). Also, thank you to Susanne Kühn for editing the past Newsletters!